

Instruction Manual

24V Brushless Rivet Gun (Auto/Manual Control Mode)

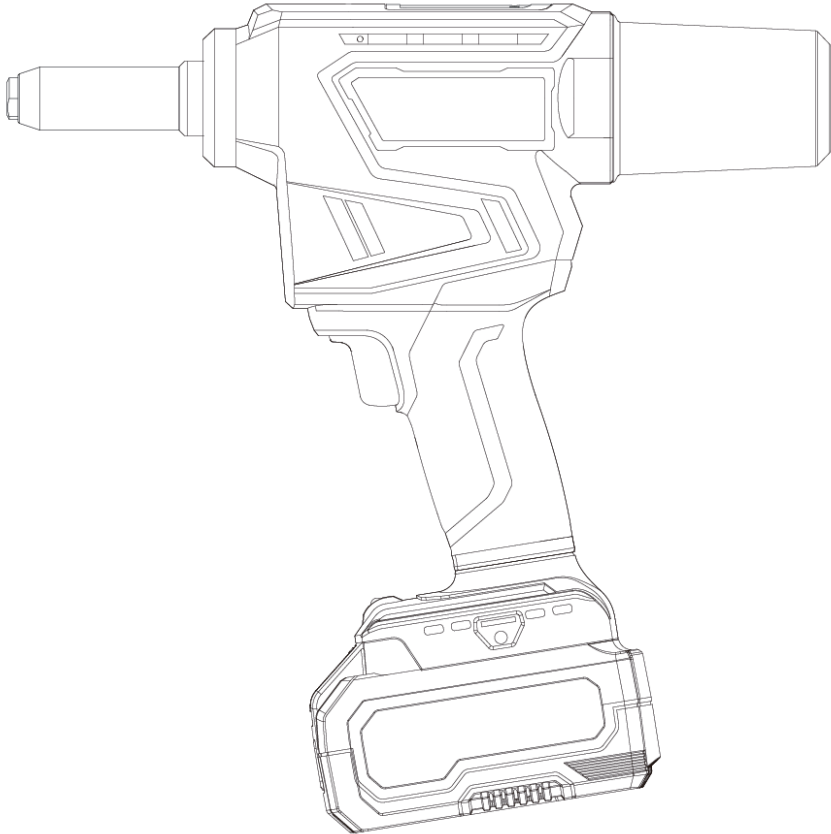

Auto control : The tool will reverse automatically if the rivet is broken. No need to press the trigger all the time. The design will increase working efficiency in riveting process and reduce operator's fatigue in the mean time.

Manual control : The tool will keep running as long as the trigger is pressed. Once the tool detects the trigger is released, it'll reverse automatically.

*All you need is pressing the trigger for 10 seconds, with the LED on foot board begins to flash, the tool will switch between auto & manual control mode.

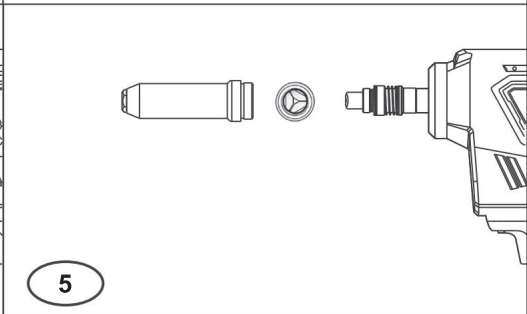
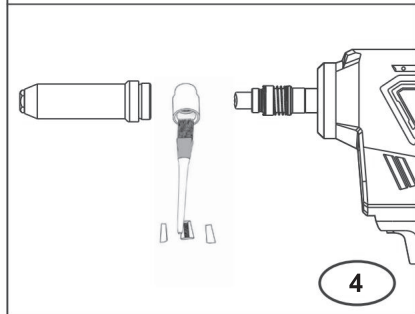
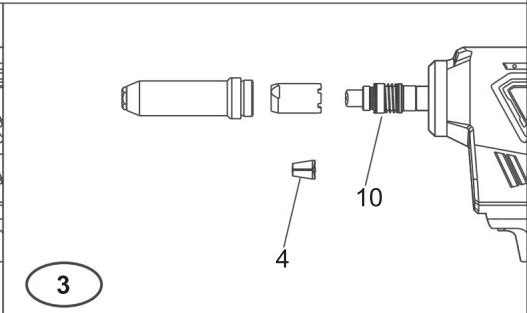
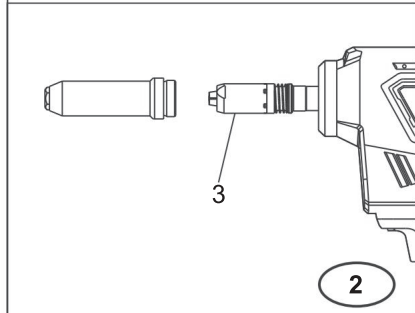
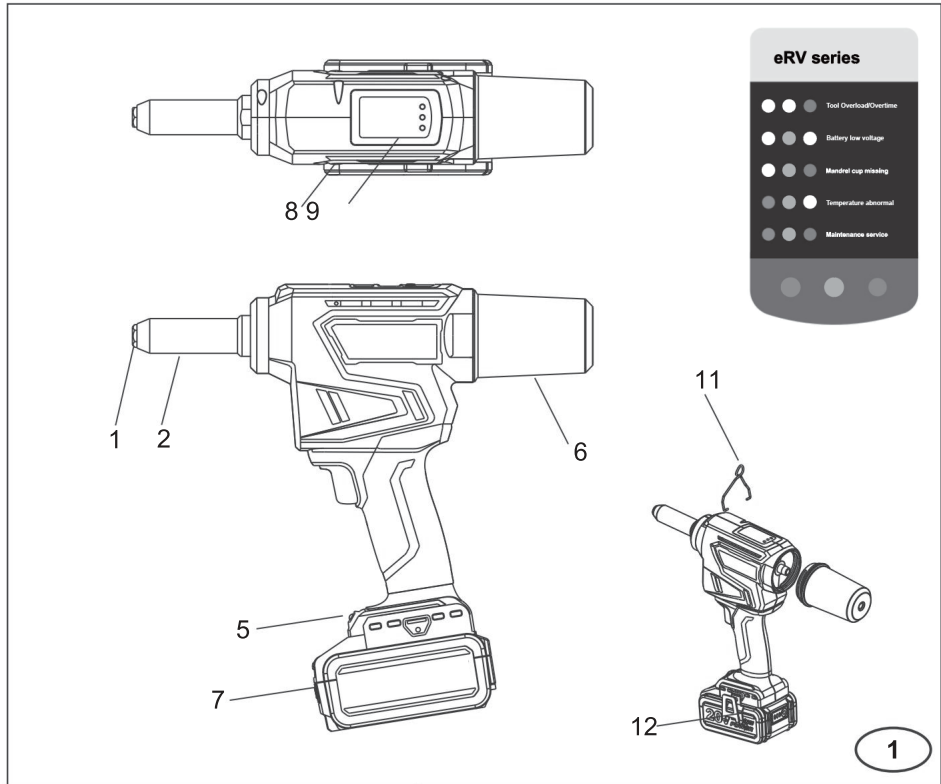

LED Warnings

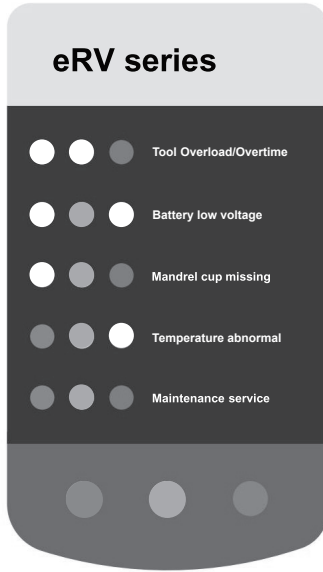

LED warning definition:

There're red, yellow and green three indicator lights on top of the tool, to indicate different status in operating. Customers would know the current status of tool through different warnings.

Green	Yellow	Red	Status	Definition
			red light flashing	Tool Overload/Overtime
			yellow light flashing	Battery low voltage
			Yellow light, green light flashing alternately	Battery low temperature/overheat
			Yellow light, green light flashing together	PCBA low temperature/overheat
			Yellow light, red light flashing together	Mandrel cup missing
			Green light, yellow light, red light flashing alternately	Maintenance Service at 300,000 or every two years

Contents

1.	Overview (see Figure 1)	2
2.	About the Riveter	2
	2.1 Intended use	2
	2.2 Safety instructions	3
	2.3 Applicable working range of rivets	3
	2.4 Specifications	4
	2.5 Configuration/Accessories	4
3.	Start	4
	3.1 Replace nosepiece	4
	3.2 Replace jaw sets	5
	3.3 Replace mandrel container	5
	3.4 Working mode switch	5
4.	How it works	5
	4.1 Installing rivets	6
	4.2 Lighting	6
	4.3 Warning	6
	4.4 Repairing	6
	4.5 Maintenance	6
5.	Quick Charger and Battery	7
	5.1 Specifications	7
	5.1.1 Quick Charger	7
	5.1.2 Battery	7
	5.2 Safety Instructions	7
	5.2.1 Quick Charger	7
	5.2.2 Battery	8
	5.3 Charging	8
	5.4 Precaution in use of battery	8
	5.5 Environmental protection	9
6.	Troubleshooting	9
	6.1 The riveter cannot be riveted normally	9
	6.2 The broken mandrel cannot be poured out	9

1. Overview (see Figure 1)

Part No	Part name	Pic
1	nosepiece	1,2,3,4,5
2	front sleeve	1,2,3,4,5
3	jaw case	1,2,3,4,5
4	jaw sets(3 pcs)	3,4,5
5	lighting LED	1
6	mandrel container	1
7	battery pack	1
8	hanger hole	1
9	controll unit asm	1
10	jaw case quick release ring	2,3,4,5
11	hanger	1
12	belt clip	1

2. Riveter

2.1 Intended use

The riveter can only be used to install rivets and similarly functioning riveted parts as per this Instruction Manual. 

Best use at temperature of 0-50°C with humidity 20-100%, indoor use only.

The tool was made of alloy parts, excessive humid environment will seriously effect the tool life.

The working site should have sufficient lighting

Always follow the safety instructions!

2.2 Safety Instructions

ATTENTION: To prevent electric shock, injury, or fire hazard, the following safety regulations must be observed:

- Do not overload the Rivet Gun; use within the specified power range.
- Do not use the Rivet Gun in wet environments or near flammable liquids and gases. Explosion hazard!
- Note that battery is fixed at the handle.
- Batteries should be removed when the Rivet Gun is not in use or maintained.
- Do not use the Rivet Gun as a striking tool.
- The Rivet Gun should be stored in a dry airtight place and beyond the reach of children.
- Always wear safety goggles when using a rivet gun. Personal protective equipment such as protective clothing, gloves, hard hat, non-skid shoes, sound-isolating earplugs, and fall arrest gear is recommended.
- Never block motor vents; never insert objects of any kind into vents.
- Place the rivet nut gun properly so that it does not fall.
- Use only original spare parts for repairs.
- Repairs should only be performed by qualified professionals. When in doubt, mail the rivet nut gun to the manufacturer.

2.3 Scope of work

2.4 to 6.4mm size - blind rivets in all materials(maximum mandrel diameter 4.5mm) *

SK LK sealing expanders - Ø3 to 14mm **

Some Huck structural rivets ***

* eRV50: 2.4 to 5.0mm size - blind rivets in all materials(maximum mandrel diameter 3.2mm)

eRV64: 4.0 to 6.4mm size - blind rivets in all materials(maximum mandrel diameter 4.5mm)

** Sealing expanders need to use with matched holding system(**optional**).

*** Huck structural rivets need to use with matched holding system(**optional**).

2.4 Specifications

Weight (without battery)	eRV50 -- 1.5kg	eRV64 -- 1.7kg
Max Stroke:	eRV50 -- 25mm	eRV64 -- 28mm
Motor:	Brushless DC Motor	
Max Pull Force:	eRV50 -- Max. 16000N	eRV64 -- Max. 21000N
Noise:	LPA 76 dB (A), measurement error K=3	
Vibration:	dB < 2.5 m/s ² , measurement error K=1.5 m/s ²	

2.5 Configuration/Accessories

Rivet nosepiece	eRV50 2.4mm - 5.0mm eRV64 4.0mm - 6.4mm
Tool	1x electric rivet gun; 1x two-end wrench (11mm &13mm)
Hook:	Optional accessories.
Belt Clip:	Optional accessories.
Quick Charger:	100V - 120V ~ /50 - 60Hz 21.6 V
Quick Charge Battery:	24V 4.0 Ah

3. Start

Before starting the rivet gun, it is necessary to select the right nosepiece that matches the part size to be riveted.

3.1 Replace the rivet nosepiece

- Press the battery pack release button, slide the battery pack 7 towards the front of the tool.
- Loosen the rivet nosepiece 1 with the wrench(SW13)
- Unscrew the rivet nosepiece 1
- Install the right nosepiece which matches the size of the rivet, and use the wrench(SW13) to tighten the rivet nosepiece 1

Tips: The nosepiece installation may be not workable when the clamping mechanism is in starting position. Keep pressing the trigger, the clamping mechanism will stay at the rear part of tool which makes the nosepiece much easier to be screwed on. Make sure the nosepiece is securely tightened by wrench, otherwise the front sleeve 2 will be damaged.

3.2 Replacing the jaws(see figures 2,3,4,5)

- Press the battery pack release button and slide it towards the front side of the tool to remove it
- Use the wrench(SW 27) to unscrew the front sleeve 2
- Push the jaw case quick release ring 10 back, unscrew jaw case 3
- Take out the jaws(a set of 3 pcs), and check the tooth surface of the jaws
- Brush a thin layer of wear-resistant grease on inner wall of jaw case 3, take out new jaws, place the tip of jaws into jaw case
- Screw jaw case 3 onto inner sleeve, make sure quick release ring 10 lock the ratchet portion of jaw case
- Use the wrench(SW 27) to tighten the front sleeve 2

3.3 Replacing the mandrel container

- .Screw(clockwise) the mandrel container(6) until it is securely fastened
- .The tool won't start and operate if the mandrel cup is not installed
- .The mandrel cup need to be removed and emptied when it is full.

3.4 Working mode switching(automatic mode and manual mode)

- .To switch the working modes, the tool has to be powered on. Press the trigger for more than 10 seconds, the LED light on foot board will flash, mode switching completed.
- .Automatic mode: To trigger the riveting process of tool, just press the switch gently and move you finger away. Once a rivet broken in pulling is detected, the tool will stop pulling back immediately, then automatically return to the starting position.
- .Manual mode: The tool will keep running as long as the trigger is pressed. Once the trigger is released or remove the finger, the tool will reverse automatically , and the rivet may not be broken yet.

4.Way of working

4.1 Install rivets

- . Insert the rivet into nosepiece, put the head of rivet into pre-hole of the workpiece till it reaches top of the nosepiece.
- . Press the trigger to start the installation process.

TIPS:

No need to press the trigger all the time under "Auto" Mode .

The operator need to manually control the riveting time during the process under "Manual" Mode.

To ensure the rivet is installed securely, the nosepiece need to be held against the workpiece firmly.

4.2 Lighting

This rivet gun is equipped with 1 high-brightness LED light for work area lighting. The light will go out and enter the Standby state if the tool is not in use for a certain period of time,15 seconds. For other lighting time setting, please contact the dealer.

4.3 Warning

This rivet gun is equipped with a complete protection mechanism and alarms through LED prompts. Users could troubleshoot according to this manual. For further assistance, please contact the dealer.



4.4 Maintenance

This rivet gun requires regular maintenance of the clamping mechanism. Trouble-free operation of the machine is not assured without the maintenance operations described.

Activity	Frequency
Visual inspection of the tool	Daily
Check on a firm fit of the clamping sleeve and re-tighten	Daily
Cleaning and greasing the clamping mechanism	3,000
Changing the clamping jaws	If the fastener can no longer be set in one stroke
Changing the nosepiece	Every 30,000 fasteners
Inspection includes the examination, service and possibly repair or replacement of all tool components, such as gearing, motor and electronics	300,000 or every two years

- From the device, press the battery pack release button and slide the battery pack 7 towards the front of the device.

Loosen the front sleeve 2 with the nut wrench(SW 27), and clean the metal chips in the front sleeve.

- Push the quick-change locking knob 10 back, unscrew the jaw sleeve 2, check and clean the metal chips in the jaw sleeve.
- Take out the clamping jaws(a set of 3 pcs), check the tooth surface of jaws.
- Take out the Jaw pusher, check whether the inclined surface needs to be replaced or not?
- Take off the Jaw pusher, check the return of the spring, whether it needs to be replaced or not?
- Remove the internal metal guide nail tube assembly, check whether the guide nail tube is blocked or damaged? It should be replaced if there's any abnormality.

There'll be a LED Warning when the rivet gun has reached 300,000 times of riveting. Regular maintenance will extend the service life of the tool. It should be serviced at **300,000** or **every two years** by an authorised service center or return to BN Products USA. For tools that used intensively, we recommend servicing ahead of schedule.

4.5 Repairing

Generally the manufacturer is responsible for warranty repairs. If the warranty period is exceeded, only professional repairs as allowed. Failure to comply with the relevant regulations for installation and adjustment, or use in accordance with the operating instructions, may result in serious damage to the tool. Any doubt, please mail the rivet gun to the supplier or BN Products USA.

5. Quick charger and battery

5.1 Specifications

5.1.1 Quick Charger

Input Voltage:	100V-120V~/50-60Hz
Output Voltage:	21.6V DC
Output Current:	4.5A

5.1.2 Battery

Rated Voltage:	21.6V
Type:	Li-ion
Capacity:	4.0 Ah

5.2 Safe instructions

5.2.1 Quick charger

Note: To prevent from any risk of electric shock, injury or fire, the following safe instructions must be followed!

- This charger can charge the original battery of the eRV electric rivet gun only!
- The plug, power cords and charger should be checked regularly. If any problems are found, they should be repaired by original service people or professional electrician.
- Use only original power cords and spare parts for repairs.
- Do not use the charger in wet or environments near flammable liquids and gases. Explosion hazard!
- Please take the charger out of the package when charging. Insert the battery into the charger with a little force, make sure it is put to the correct electrode directions.
- Do not charge non-rechargeable batteries.
- Store the charger in a dry and airtight place, keep away from children.
- Do not place metal objects into charging area to avoid short circuits.
- If the charger is mounted on a wall, make sure that the battery can not fall out of the charger due to external influences such as vibration.
- This charger should not be used by handicapped, mentally handicapped or untrained and uninformed persons unless supervised by a person in charge of safety on site, or who can instruct them on how to use the charger.

5.2.2 Battery

Note: To prevent from any risk of electric shock, injury or fire, the following safe instructions must be followed!

- Do not charge damaged batteries.
- Do not place soiled or wet batteries in the charger.
- Never throw batteries into trash, fire or water!



5.3 Charging

- Only charge the battery at temperatures between -5°C and +50°C!
- Take the charger out of the packaging and plug it into a power source.
- Insert the battery into the charger, ensure the correct orientation of the poles, put a little force when inserting.
- The quick charger will start charging automatically.

Charge indicators

Signal	Definition
Green constant	Power on, standby
Insert battery pack, Red constant	Quick charging
Insert battery pack, Green constant	Fully charged

5.4 Using the battery

- Insert the charger only when the battery has cooled sufficiently.
- The original battery can be recharged more than 500 times, but battery life'll shorten after 500 cycles.
- Do not recharge the battery every time after  or only when power is completely running out.
- The battery need to be replaced if the power  running out too fast.
- Do not expose the battery in freezing temperature, store it in a dry place. The ideal temperature for battery use is 10°C-50°C.

There's a Charge Gauge to indicate the remaining Battery capacity. Press the Charge Gauge Button on the Battery to check its remaining run time.

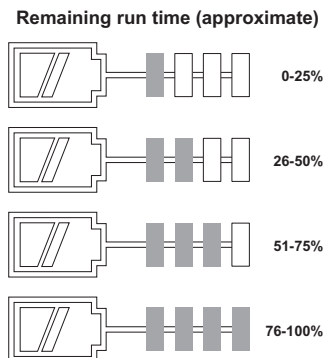

The battery capacity which is showed on Charge Gauge is only for reference, it's more accurate on tool's screen.

5.5 Environmental protection

When the battery must be replaced, please note the following:

- Please hand over the old battery to the dealer or BN products USA for recycling.
- Never dispose old batteries into trash, fire or water!

6. Troubleshooting

6.1 The riveting gun cannot be riveted normally

Reasons	Remedy
Grease on jaw teeth, or teeth worn out	Replace with new jaws
Nosepiece tip damage	Replace the rivet nosepiece
Jaw spreader spring was aging over compressed, can't have enough force	Replace spring
Battery drained in LED "low battery alarm"	Charging(see chapter 5.3)

6.2 Broken mandrel can't go through into the mandrel cup

Reasons	Remedy
Wrong type of riveting nosepiece	Use a suitable rivet nosepiece
Mandrel guide tube damaged	Replace the guide tube
Mandrel cup is full	Need to empty the mandrel cup
Other objects or metal chips in the front sleeve	Clean the front sleeve